

## ultra-high performance for scanning mirror applications

### optoSiC-PLUS<sup>®</sup> XY100G

optoSiC-PLUS<sup>®</sup> XY100G generic scanning mirrors are designed using a unique protected spine and rib structure mirror at < 100,0 mm aperture.

These mirrors are manufactured as optoSiC-PLUS<sup>®</sup> grade a unique Silicon Carbide to give optimum stiffness, dynamic flatness and high resonant frequencies under high torque loadings while offering very low Moment of Inertia for all moving applications where processing speed and precise performance is paramount.

optoSiC-PLUS<sup>®</sup> XY100G generic scanning mirrors are available and standard polished to interferometric controlled wavefront-error of e.g.  $1/4 \cdot \lambda$  PV @632,8nm, ( $2 \cdot \lambda \dots 1/8 \lambda$  on request) either can be coated for 10,6 $\mu$ m- CO<sub>2</sub>, 1064nm for Nd:YAG IR, 532nm for frequency doubled Nd:YAG VIS, 355nm UV or many other coatings on request. Please refer to technical datasheets for coatings available on optoSiC-PLUS<sup>®</sup> or see download-links on homepage and ask our sales people for further choices on coatings and mounts.

CHOICES for Mounted Mirrors		X	Mirror	Y
Type	SM			
	OS			

GENERAL	PROPERTIES	Typical values	
MIRROR SPECS	Surface Roughness Ra	< 0,5 nm (polished)	
	Wavefront error	$1/4 \lambda$ PV @ 632,8nm interferometric within CA	
	Aperture	collimated full beam diameter on X+Y is 100,0 mm	
MIRROR-TYPE		x 100G	y 100G
	Mass (g)	216	495,4
	Moment of Inertia (g*cm <sup>2</sup> )	1.987	2.899
	Resonant Frequency (kHz)	4,17	3,37
	Dynamic Flatness (pm/(rad/s <sup>2</sup> ))	157	160
	Optical axis hight on rot.axis (mm)	61,5	113,8
	Angle of Incidence (°)	45	37,5
	x-y Separation (mm)	126,5	-
	x-Tilt (°)	-17	-
	Mechanical Scan Angle (°)	±10,0	-

The Dynamic Flatness is a normalized measure given as the max. deformation (PV) of the mirror surface at a angle acceleration rate of 1 rad/s<sup>2</sup>

<i>Mirror Type:</i>	<b>X100G</b>	<b>Y100G</b>
---------------------	--------------	--------------

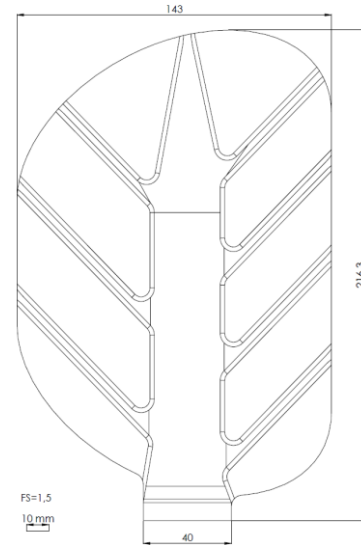
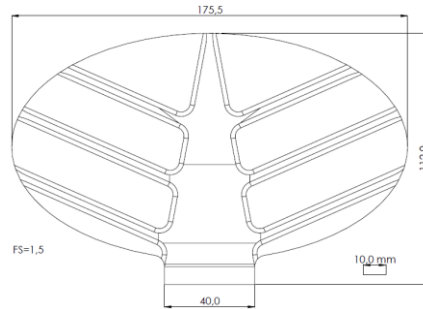

**MATERIAL DEPENDING CHARACTERISTICS:**

Density [ $\rho$ ]	> 3,16	g/cm <sup>3</sup>	[ DIN EN 623-2 ]	
Flexual Strength [ $\sigma_B$ ]	510	MPa	[ DIN EN 843-1 ]	
Young's Modulus [E]	420	GPa	[ DIN EN 843-2 ]	
Weibull Modulus [m]	15		[ DIN EN 843-5 ]	
Poisson's Ratio [ $\nu$ ]	0,17			
Fracture Toughness [SENB]	4,0	K <sub>IC</sub> [MPa*m <sup>0.5</sup> ]		
Vickers Hardness	25,5	HV 1 (GPa)	[ DIN EN 843-4 ]	
Open Porosity	0%			
Mean Grain Size	< 2,5	$\mu\text{m}$ typ. 1,5 $\mu\text{m}$		
CTE [ $\alpha$ ] (TEC) Coefficient Thermal Expansion	4,1 2,5	[10 <sup>-6</sup> /°K] 20-500°C [10 <sup>-6</sup> /°K] 15-25°C	[ DIN EN 821-1 ]	
Thermal Stress [Ri]	246 37	R <sub>1</sub> [K] R <sub>2</sub> [W/mm]	R <sub>1</sub> = $\sigma_B \cdot (1 - \nu) / (\alpha \cdot E)$ R <sub>2</sub> = R <sub>1</sub> * $\lambda$	
Heat Capacity [cp]	20°C 1000°C	0,67 1,27	J/g * K	Specific heat cp (dynamic DSC, DIN EN 821-3)
Heat Conductivity [ $\lambda$ ]	20°C	150	W/m K @ 20°C	Calculation of thermal conductivity TC based on thermal diffusivity a (Laser-Flash, DIN EN 821-2), specific heat cp (dynamic DSC, DIN EN 821-3), and density (corrected for the thermal expansion TEC, DIN EN 821-1)
Thermal Conductivity [TC]	1000°C	54	kJ/m * h * K	

The specification or data herein contained are only given for indication, without any undertakings whatsoever. Their publication does not suggest the matter is free of any rights whatsoever. Furthermore, due to constant evolution of techniques and norms, we reserve the right to modify, at any time, the characteristics and specifications contained in this document. MERSEN refuses all and any responsibility concerning their use whatever the purpose or application. Any copy, reproduction or information herein contained, in whole or in part, made without MERSEN written consent, is forbidden according to the laws of France and particularly the law nr. 92-597 of July 1st 1992 relating to the copyright.

**Please Contact:**

**MERSEN Deutschland Holding GmbH & Co. KG**  
 Branch: Baden-Baden  
 Lange Straße 89a  
 D-76530 Baden-Baden  
 Germany

Phone: +49 (0) 7221 973974 0  
 Fax: +49 (0) 7221 973974 211  
 E-Mail: [info@optoSiC.com](mailto:info@optoSiC.com)  
[www.optosic.mersen.com](http://www.optosic.mersen.com)